

مؤتمر ومعرض الكويت الثاني للأسمنت والخرسانة  
**THE 2<sup>ND</sup> KUWAIT CEMENT AND CONCRETE**  
CONFERENCE & EXHIBITION 08-09 FEBRUARY 2012 RADISSON BLU HOTEL

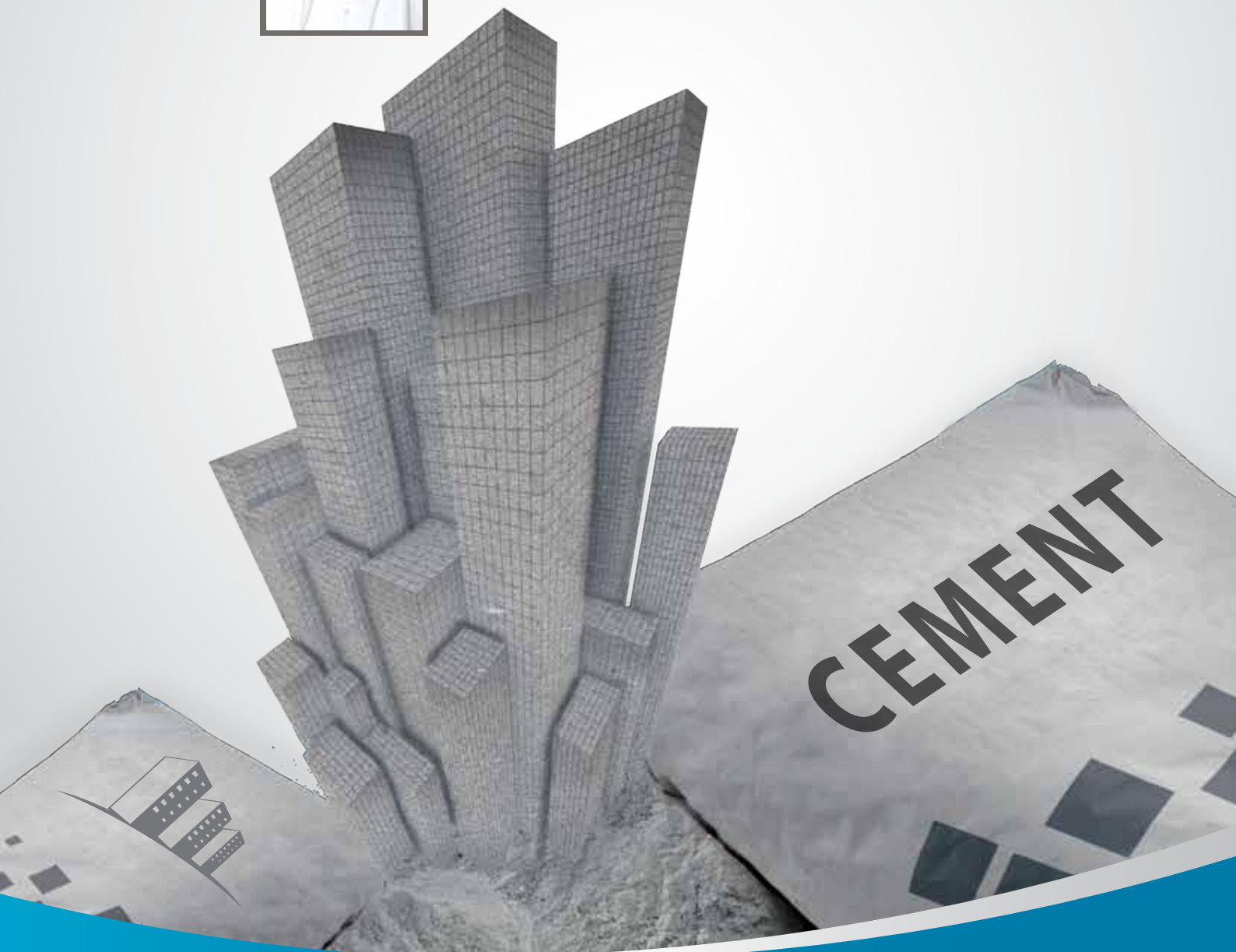

UNDER THE PATRONAGE OF  
H. E. DR. FADEL SAFAR ALI SAFAR  
MINISTER OF PUBLIC WORKS AND  
STATE MINISTER OF MUNICIPAL AFFAIRS, KUWAIT



Organized by

**ProMedia**  
International بروميديا العالمية  
www.promediakw.com

Tel : +965 2434 2929

Fax : +965 2433 0809

www.kccce.com

## CONFERENCE :

### OVERVIEW :

The Kuwaiti government plans to spend up to KWD 40bn (USD 139.9bn) on its proposed five-year development plan which runs until 2014. Within this state plan, several massive construction projects are planned to take place in the near future. This will create huge demand for cement and other building materials. The Kuwait Cement and Concrete Conference and Exhibition aims to be the educational and networking platform which provides insights on the latest developments and technologies related to the cement and concrete industry.

The Kuwait Cement and Concrete Conference and Exhibition aims to present the latest advances related to the study and use of cementitious materials and cutting-edge developments in the science and engineering of construction concrete. The event will bring together academics and industrialists, researchers and practitioners, engineers and scientists, all of whom will be presenting up-to-the-minute results looking at the performance and properties of cement and concrete.

This two-day conference will address societal and sustainability concerns, including environmental impact, durability and lifetime prediction, material recycling, low energy materials, building codes, maintenance and repair of structures and concrete in hot and aggressive environments.

The Kuwait Cement and Concrete Conference and Exhibition is committed to focusing on the current concerns of cement and concrete professionals and to address local and world-wide problems through presentations, seminars and workshops along with a selection of keynote addresses and technical papers to make this conference highly beneficial to professionals involved in the world of concrete.

### WHO SHOULD ATTEND?

- Cement manufacturers and producers
- Concrete and ready-mix companies
- Contractors and subcontractors
- Government officials
- Project financiers and managers
- Architects, civil engineers and consultants
- Raw material suppliers
- Technology suppliers
- Traders



تتقدم اللجنة المنظمة للمؤتمر بأطيب تحياتها وتتهني لشخصكم الكريم دوام الصحة والنجاح .

تحت رعاية وحضور معالي وزير التشغيل العاهة وزير الدولة للشئون البلدية الدكتور فاضل صفر ، تنظم شركة بروميديا العالمية مؤتمر ومعرض الكويت الثاني للإسمنت والخرسانة خلال الفترة من ٨ - ٩ فبراير ٢٠١٢ بفندق راديسون بلو -قاعة بوبيان .

تزامنا مع ما تسعى اليه الدولة من تنفيذ خطتها التنموية والتي تقدر ميزانيتها ٣٨ مليار دينار كويتي حيث سيتم تنفيذ مجموعة من المشاريع الكبرى مما يتطلب توفر كميات ضخمة ومتنوعة من الاسمنت والخرسانة .

بعد النجاح الذي حققه مؤتمرنا ومعرضنا الأول ، وذلك بشهادة مجموع الشركات المشاركة به سواء من داخل الكويت او خارجه ، فقد قررت اللجنة المنظمة تكرار هذا المؤتمر وذلك لما طرأ عليه من مستجدات وتطورات وتقنيات حديثة في عالم صناعة الاسمنت والخرسانة . وكذلك تبادل الخبرات مع المتخصصين من أهل الصناعة .

لذا فإننا ومن خلال مؤتمر ومعرض الكويت الثاني للإسمنت والخرسانة نهدف إلي نشر واتساع مساحة الاستفادة من العلوم الحديثة لتكون منصة تعليمية ومعرفية تزود من خلالها أهل الصناعة بأحدث التطورات والتقنيات المرتبطة بصناعة الاسمنت والخرسانة بما سيتضمنه المؤتمر من أحدث الدراسات واستخدام المواد الإسمنتية والتطورات الحاصلة في علم وهندسة خرسانة البناء، وسوف يجمع هذا الحدث مجموعة من الأكاديميين والصناعيين والباحثين والممارسين والمهندسين الذين سيقدمون آخر النتائج والحلول العلمية والعالمية المتعلقة بأداء وخواص الاسمنت والخرسانة لتقديمها للمشاركين.

كما سيناقش المؤتمر علي مدي يومين قضايا بالمجتمع والاستدامة تتضمن التأثيرات البيئية وكفاءة المنتجات الإسمنتية، وإعادة التدوير، ومواد قليلة الاستهلاك للطاقة، وأكواد البناء، صناعة وإصلاح المباني الخرسانية، ودراسة الخرسانة في البيئات الحارة والقاسية.

**اوقات المؤتمر : ٩ صباحا - ٣ عصرا .**

**علمها بان رسوم المشاركة بالمؤتمر ( ٣٠٠ دينار للفرد الواحد ) .**



## ورشة العمل :

ستقيم اللجنة المنظمة ورشة عمل بعنوان (ال مواد المستحدثة المسلحة بالالياف وتطبيقاتها الحديثة في الخرسانة المسلحة) ،  
يحاضر بها كلا من :

- أ.د. عبد الحكيم خليل (نائب رئيس الجامعة لشئون التعليم والطلاب جامعه طنطا ، أستاذ المنشآت الخرسانية ) .
- د. عهاد السيد احمد عثمان ( استاذ مساعد بكلية الهندسة جامعه طنطا ) .

تاريخ ورشة العمل : ٧ فبراير ٢٠١٢

المكان : فندق راديسون بلو - قاعة الهاشمي .

اوقات ورشه العمل : من ٩ صباحا - ٣ عصرا .

علما بان رسوم المشاركة بالورشة ( ١٥٠ دينار للفرد الواحد ) .

كما أننا نتطلع إلي مشاركتكم وكذلك ترشيح مجموعة من الموظفين لحضور  
هذا المؤتمر وورشة العمل .

### المحاور

ال مواد البوليمرية الاسمنتية.  
الخرسانة المسلحة بالانسجة.  
ال مواد الاسمنتية ذات اساس معدني  
لتقوية العناصر الخرسانية.

### المستهدفون

ال مهندسون  
ال باحثون  
ال استشاريون



## WORKSHOP :

Workshop: **Advanced Fiber Reinforced Materials and Recent Applications in Reinforced Concrete**

Date: 07 February 2012

Time: 09:00 – 15:00

Venue: Radisson Blu Hotel

Fees: KD 150

Instructors:

**Prof. Dr. Abdel-Hakim Abdel-Khalek Khalil**

Vice President of Tanta University for Education and Students

Professor of Concrete Structures

**Prof. Dr. Emad El-Sayed Etman**

Director of Research and Engineering Consultant Center

Professor of Concrete Structures

## TOPICS

- Polymeric Cementitious Composites
- Textile Reinforce Concrete
- Mineral Based Cementitious Composites for the Strengthening of RC Elements

## WHO SHOULD ATTEND ?

ENGINEERS  
RESEARCHERS  
CONSULTANTS

## Call for Papers :

The theme of the conference is “Towards Efficient, Durable, Sustainable Cement and Concrete industry”. The scientific committee invites authors to submit papers related to the theme with particular interest in the following areas:

- Advances in Chemical Admixtures
- Advances in Supplementary Cementitious Materials & Fibers
- Structural performance and design
- Material selection and mix design
- Specialty Concretes
- High-Performance Concrete
- Durability of Concrete Structures
- Workability and rheology
- Specifications, Testing and Performance
- Design & Sustainability Standards
- Economic and environmental benefits



The official language of the conference will be English. Papers, however, may be also submitted and presented in Arabic.

All those interested in submitting papers are requested to submit an abstract of 200-300 words, accompanied by the name(s) of author(s), affiliations, mailing address and e-mail address. Dead line for receiving abstracts is 30/11/2011.

Please send abstracts to: [hudhaib@promediakw.com](mailto:hudhaib@promediakw.com)



## Exhibition :

### GENERAL INFO :

**Venue:** Radisson Blu Hotel, Kuwait

**Date:** 8 & 9 Feb. 2012.

**Timing:** 09:00 am – 17:00 pm.

**Kuwait Cement and Concrete Conference & Exhibition** is the perfect environment for you to engage in “face to face” meetings. This is the place where you can make new and long lasting business relationships in a fast developing market.

### EXHIBITION RATES :

The cost of one stand is **1,500KD** which includes **9sqm** of floor space, shell scheme, fascia board with company name, 4 spotlights, 1 table, 2 chairs and electrical socket.

#### Co-Exhibitor Policy

If you plan to share your booth space with another companies (**co-exhibitors**) , there is an additional fee of **200 KD** for each co-exhibitor. This entitles the co-exhibitor to a listing in the event website, show directory, company name on fascia board and exhibitor badges with their company name.

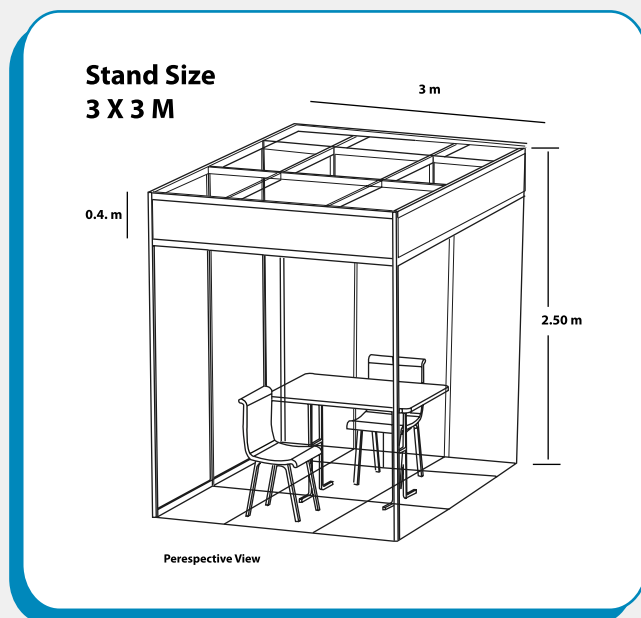

## VISA INFORMATION :

Visas can be obtained on arrival for many nationalities, while others may be obtained through application beforehand. Please contact your hotel representative for your visa arrangements.

### NATIONALITIES THAT CAN GET THEIR VISA DIRECTLY AT THE AIRPORT ARE:

Australia, Austria, Andorra, Belgium, Brunei, Canada, Denmark, France, Finland, Germany, Greece, Holland, Hong Kong, Ireland, Italy, Iceland, Japan, Luxembourg, Lechtein, Malaysia, Monaco, New Zealand, Norway, Portugal, Switzerland, Spain, San Marino, Singapore, South Korea, Sweden, USA, UK, Vatican.

## المعرض :

- واللجنة المنظمة للحدث تدعو من خلال المعرض المصاحب للمؤتمر المهتمين في المعرض وهم :
- مصنعي ومنتجات الاسمنت وشركات الخرسانة والخط الجاهزة
  - والمقاولين والمسؤولين الحكوميين
  - وهذراء المشاريع
  - وموردي مواد الخار
  - والشركات الإنشائية ومقدمي حلول تكنولوجية
  - والهكاتب الهندسية
  - والتجار وجميع المهتمين بهذه الصناعة إلى المشاركة لعرض منتجاتهم

## FLOOR PLAN :

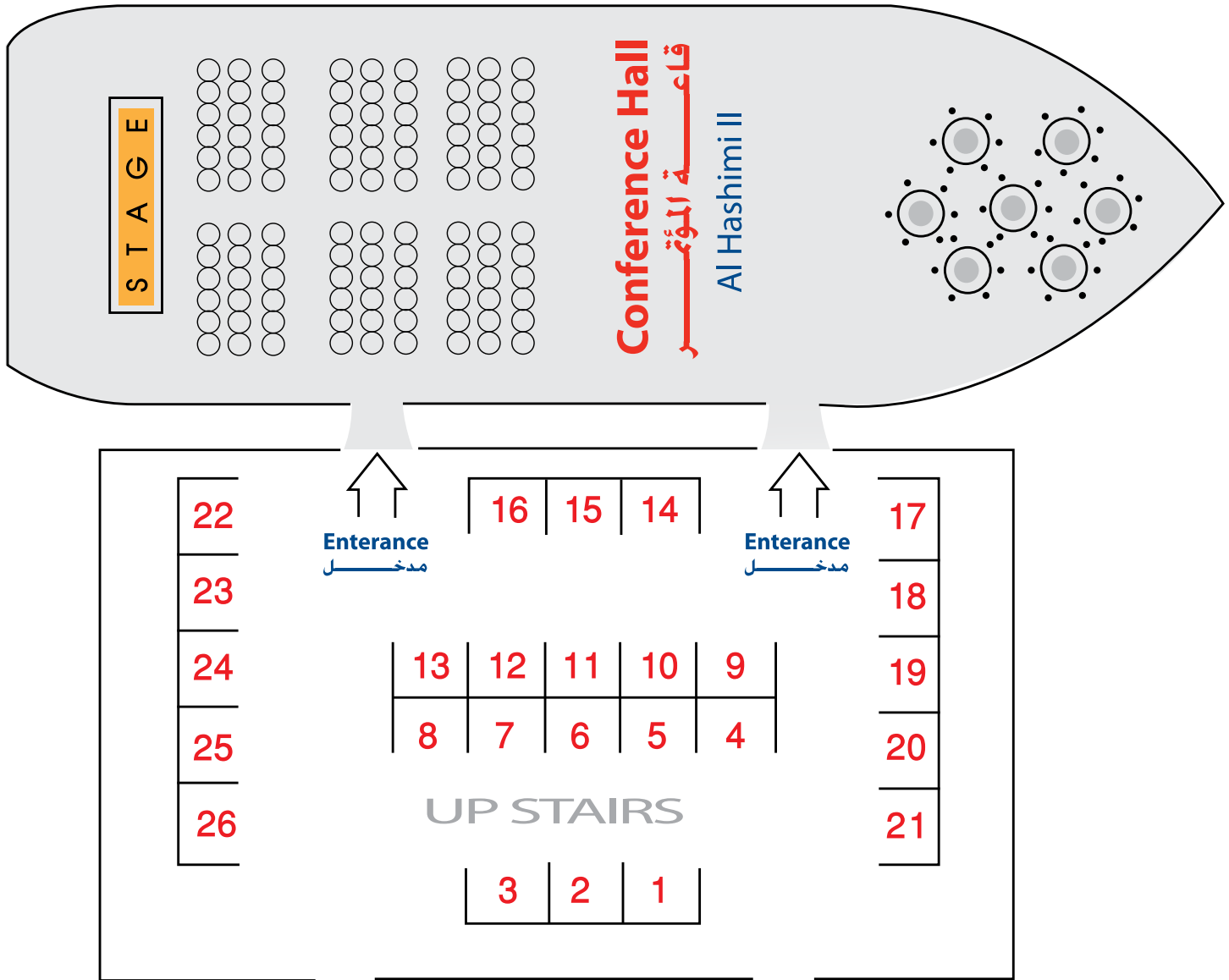

## Sponsorship :

**Kuwait Cement and Concrete Conference & Exhibition** offers Main, Gold and Silver levels of sponsorship. Each of these sponsorship packages offers benefits to showcase your company as a sponsor of the event.

### MAIN SPONSOR

**Price: 9000 KD**

**Each sponsor will receive:**

- » Three free booths ( 27 sqm)
- » Speaking opportunity at the opening ceremony.
- » 15 complimentary full conference registration.
- » Two banner location (2 x 1 m) inside the exhibition hall (production & fixing by sponsor).
- » Logo & Company Name in all printings and promotional materials for the event.
- » Logo on event website with link to sponsor's home page.
- » Provision for flyer distribution at Exhibition Entrance.
- » VIP invitations to attend Opening Ceremony.
- » Award & Appreciation Certificate for sponsorship.

### GOLD SPONSOR

**Price: 6000 KD**

**Each sponsor will receive:**

- » Two free booths (18 sqm)
- » 10 complimentary full conference registration.
- » Two banner location (2 x 1 m) inside the exhibition hall (production & fixing by sponsor).
- » Logo & Company Name in all printings and promotional materials for the event.
- » Logo on event website with link to sponsor's home page.
- » Provision for flyer distribution at Exhibition Entrance.
- » VIP invitations to attend Opening Ceremony.
- » Award & Appreciation Certificate for sponsorship.

### SILVER SPONSOR

**Price: 3000 KD**

**Each sponsor will receive:**

- » One free booth ( 9 sqm)
- » 6 complimentary full conference registration.
- » One banner location (2 x 1 m) inside the exhibition hall (production & fixing by sponsor).
- » Logo & Company Name in all printings and promotional materials for the event.
- » Logo on event website with link to sponsor's home page.
- » Provision for flyer distribution at Exhibition Entrance.
- » VIP invitations to attend Opening Ceremony.
- » Award & Appreciation Certificate for sponsorship.

## Sponsorship :

### SPONSORSHIP OPPORTUNITIES :

#### Conference Luncheon

**Price : 2000 KD**

Each day buffet luncheon will be provided at the Radisson Blu Hotel to conference guests & registrants. These luncheons will provide attendees with the opportunity for networking and offer the sponsor an avenue to demonstrate hospitality to conference delegates. The sponsor of each luncheon will receive:

- » Company's name and logo prominently displayed on acknowledgement cards on all the buffet tables.
- » Company information (if desired) to be available at the entrance.
- » Two (2) complimentary full conference registrations.
- » Logo on event website with link to sponsor's home page.
- » VIP invitations to attend Opening Ceremony.
- » Award & Appreciation Certificate for sponsorship.

#### Delegate Bages

**Price : 2000 KD**

All delegates with full registration will receive one delegate bag containing information and materials on the conference. Approximately 500 bags will be made. The sponsor will receive:

- » Company's name and logo prominently displayed on acknowledgement cards on all the buffet tables.
- » Company information (if desired) to be available at the entrance.
- » Two (2) complimentary full conference registrations.
- » Logo on event website with link to sponsor's home page.
- » VIP invitations to attend Opening Ceremony.
- » Award & Appreciation Certificate for sponsorship.

#### Conference CD

**Price : 1500 KD**

Being the most important technical documentation for the conference, the CD-ROM Proceedings contain papers which are presented at the conference. All full conference registrants will receive a CD at the Conference. The sponsor will receive:

- » Acknowledgement on the introductory screen inside the Proceedings.
- » Two (2) complimentary full conference registrations.

#### Conference USB

**Price : 1500 KD**

Your company logo will be printed on the front of the USB stick. The USB contains conference proceedings and event guide. The sponsor will receive:

- » Acknowledgement on the introductory screen inside the Proceedings.
- » Two (2) complimentary full conference registrations.

#### Conference Pens

**Price : 1000 KD**

Conference writing pens will be included in the delegate bags. The sponsor will receive:

- » Company's name and logo on the pens.
- » One (1) complimentary full conference registration.

#### Conference Pads

**Price : 1000 KD**

Conference writing pads will be included in the delegate bags. The sponsor will receive:

- » Company's name and logo on the writing pads.
- » One (1) complimentary full conference registration.

#### Registration

**Price : 1000 KD**

An ideal way to display your company's name and logo, the badge holders and lanyards will be distributed to the delegates with their conference material. The sponsor will receive:

- » Sponsor logo on conference badge holder or lanyard
- » Signage with sponsor logo at registration desk.
- » One (1) complimentary full conference registration



**APPLICATION FORM :**

Companies are invited to sponsor the event  
Please refer to the sponsorship benefits or visit the conference website : [www.kccce.com](http://www.kccce.com)

Our company is pleased to sponsor the event as follow :			
<input type="checkbox"/> Main Sponsor	9000 KD	<input type="checkbox"/> Conference USB	1500 KD
<input type="checkbox"/> Gold Sponsor	6000 KD	<input type="checkbox"/> Writing Pens	1000 KD
<input type="checkbox"/> Silver Sponsor	3000 KD	<input type="checkbox"/> Writing Pads	1000 KD
<input type="checkbox"/> Conference Lunch	2000 KD	<input type="checkbox"/> Registration	1000 KD
<input type="checkbox"/> Delegate bags	2000 KD	<input type="checkbox"/> Conference CD	1500 KD

The cost of one stand is 1,500 KD (5400US\$) which includes (9sqm) of floor space, shell scheme, fascia board with company name, 4 spotlights, 1 table, 2 chairs and electrical socket.

No. of Stands Required

Stand Number(s)

Company \_\_\_\_\_

Contact Person \_\_\_\_\_

Mailing Address \_\_\_\_\_

City \_\_\_\_\_ Country \_\_\_\_\_ Postal Code \_\_\_\_\_

Telephone \_\_\_\_\_ Fax \_\_\_\_\_ Email \_\_\_\_\_

Signature \_\_\_\_\_

Date \_\_\_\_\_

**Please Choose From Following:**

- Full payment must be received prior to the conference. please invoice my organization (authorization attached)
- I will be sending a Bank transfer to  
Account Name: Promedia International Company.  
Bank: Kuwait Finance House  
Account #: 021010058612  
Swift Code: KFHOKWKWXXX  
IBAN : KW50 KFHO 00 0000 0000 021010058612
- I enclosed a cheque made payable to Promedia International Company.

Please mail or fax this form to :

**ProMedia**  
International بروميديا العالمية  
[www.promediakw.com](http://www.promediakw.com)

Tel : +965 2434 2929 P. O. Box 1242 Dasman  
Fax : +965 2433 0809 Postal code: 15462 - Kuwait  
[cd@promediakw.com](mailto:cd@promediakw.com)  
Mobile : +965 2434 2929

مؤتمر ومعرض الكويت الثاني للإسمنت والخرسانة  
**THE 2<sup>ND</sup> KUWAIT CEMENT AND CONCRETE**  
CONFERENCE & EXHIBITION 08-09 FEBRUARY 2012 RADISSON BLU HOTEL



**Radisson** **BLU**  
HOTELS & RESORTS

## Visa

Visas can be obtained on arrival for many nationalities, while others may be obtained through application beforehand. Please contact your hotel representative for your visa arrangements.

### **Nationalities that can get their visa directly at the airport are**

Australia, Austria, Andorra, Belgium, Brunei, Canada, Denmark, France, Finland, Germany, Greece, Holland, Hong Kong, Ireland, Italy, Iceland, Japan, Luxembourg, Lechtein, Malaysia, Monaco, New Zealand, Norway, Portugal, Switzerland, Spain, San Marino, Singapore, South Korea, Sweden, USA, UK, Vatican.

# مؤتمر ومعرض الكويت الثاني للإسمنت والخرسانة

## THE 2<sup>ND</sup> KUWAIT CEMENT AND CONCRETE CONFERENCE & EXHIBITION

**F A X** To : +965 2434 2929

**Registration Form**

08-09 FEBRUARY 2012

RADISSON BLU HOTEL



### Registration Form

Name :				الاسم :	
Job Title :				المنصب :	
Organization :				الشركة / الجهة :	
Address :	العنوان :	Country :	الدولة :		
P.O. Box :	ص.ب. :	Postal Code :	الرمز البريدي :	City :	المدنية :
Telephone :					هاتف :
Fax :					فاكس :
Mobile :					النقال :
Email :					البريد الإلكتروني :
Date :	التاريخ :	Signature :	التوقيع :		

#### Conference Fees: 2

- The 2<sup>nd</sup> Kuwait Cement & Concrete conference & Exhibition, 08 - 09 Feb. 2012 ..... (300 K.D.)
- Workshop: Advanced Fiber Reinforced Materials and Recent Applications in Reinforced Concrete 07 February 2012 ..... (150 K.D.)

The Registration Fee Includes Full Conference Package With :

- 1 - Conference Proceedings
- 2 - Admission to all the Technical Sessions
- 3 - Opening Ceremony
- 4 - Daily Lunches & Coffee Breaks
- 5 - Certificate of Attendance

Accommodations are NOT included in the registration fee

#### Payment Details: 3

Please Choose From Following:

- Full payment must be received prior to the conference. please invoice my organization (authorization attached)
- I will be sending a Bank transfer to  
Account Name: Promedia International Company.  
Bank: Kuwait Finance House  
Account #: 021010058612  
Swift Code: KFHOKWKWXXX  
IBAN : KW50 KFHO 00 0000 0000 021010058612
- I enclosed a cheque made payable to Promedia International Company.

Please fax confirmation of the bank transfer to +965 25317604, quoting delegate's name as your reference on both fax and bank transfer.

#### Cancellations: 4

Cancellations must be made in writing.  
A 75% refund will be given for cancellations made two months Before and 50% refund will be given for one month before cancellations.

#### Group Discounts: 5

There will be 10% discount on registration of more than 5 delegates from one organization.

Organized by

**ProMedia**  
International  
www.promediakw.com

Tel : +965 2434 2929

Fax : +965 2433 0809

www.kccce.com

www.promediakw.com